

MIRROR-LUX[®]



**Introducing the wheelchair
Angled Mirror in compliance
with the ADA (Americans with
Disabilities Act)**

Ideal for handicapped suites in hotels, nursing homes, hospitals and public restrooms.

The ADA Angled Mirror comes in several sizes that conform to federal regulations.

AAMSCO LIGHTING, INC.
1-800-221-9092

Residential – Hospitality – Custom
www.aamsco.com



TECHNICAL AND ORDERING DATA
for Models 4018, 4024, 4036

Wheelchair Mirror

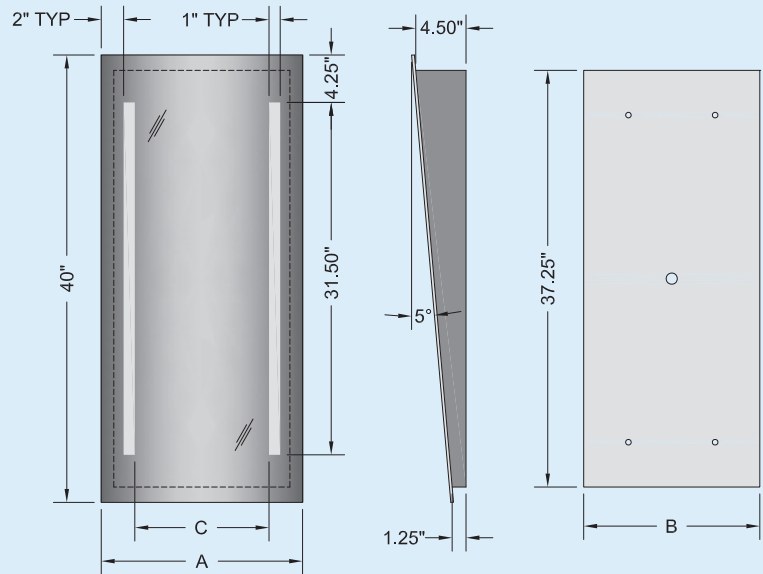
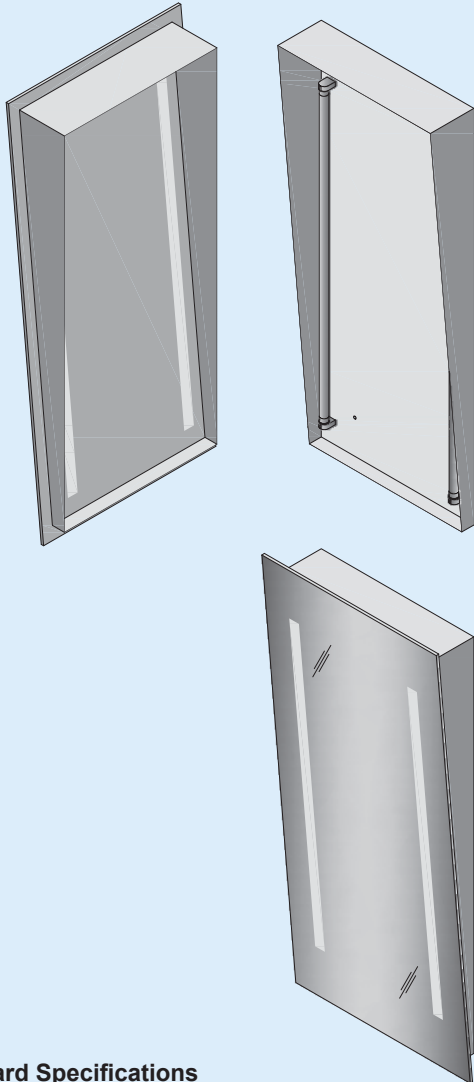

Model #	4018	4024	4036
WIDTH DIMENSIONS			
A	18"	24"	36"
B	15.75"	21.75"	33.75"
C	12"	18"	30"

Standard Specifications

- Voltage: 120 (220 & 277 available, consult factory)
- Ballast: Electronic high power factor
- Mounting: Mounting holes (four) provided for mounting to mechanically sound surface
- ETL Listed (U.S.A. & Canada) for damp locations
 ADA: Conforms to the regulations of the Americans with Disabilities Act

- SANDBLASTED WINDOW SECTION 1" WIDE X 31.5" HIGH
- BULB TO BE F21T-5 X 2 34"
- ELECTRONIC BALLAST
- RE-LAMPING BY REMOVING GLASS
- PLEASE ALLOW SPACE AT THE SIDES OF MIRROR FOR RELAMPING
- ADA MIRROR COMES WITH 2 THUMB SCREWS FOR RELAMPING, TAMPER PROOF SCREWS ARE AVAILABLE UPON REQUEST

Please note AAMSCO reserves the right to vary placement of inserts and mounting features to accommodate manufacturing tolerances. Specifications outlined are subject to +/- 1/8" variance.

* For custom shapes and sizes, please consult factory.

AAMSCO LIGHTING, INC.

100 Lamp Light Circle
 Summerville, SC 29483
 Phone 843-278-0000
 Fax 843-278-0001

Residential – Hospitality – Custom
www.aamsco.com

The intelligent alternative sourcesm

