



AAMSCO LIGHTING, INC.  
100 Lamp Light Circle  
Summerville, SC 29483  
800-221-9092  
[www.aamsco.com](http://www.aamsco.com)

## INSTALLATION INSTRUCTIONS

### CORNCOB LED

#### **CAUTION--READ THIS FIRST--IMPORTANT SAFETY INSTRUCTIONS**

- Carefully read the instructions pertaining to this product. If you have any questions regarding the proper installation or local codes, consult a qualified electrician.
- This product is intended for connection directly to mains voltage.
- To avoid shock hazard, do not work with live electrical wires.
- This product can be installed in both indoor and outdoor locations.



**WARNING: THIS PRODUCT MUST BE INSTALLED IN ACCORDANCE WITH THE APPLICABLE INSTALLATION CODE BY A PERSON FAMILIAR WITH THE CONSTRUCTION AND OPERATION OF THE PRODUCT AND THE HAZARDS INVOLVED.**



**WARNING: TO AVOID SHOCK HAZARD, DISCONNECT THE POWER AT THE CIRCUIT BREAKER BOX BEFORE BEGINNING INSTALLATION.**



AAMSCO LIGHTING, INC.  
100 Lamp Light Circle  
Summerville, SC 29483  
800-221-9092

[www.aamsco.com](http://www.aamsco.com)

## INSTALLATION INSTRUCTIONS CORNCOB LED

**As an Incandescent replacement, simply install directly into existing socket.**

**As an HID or CFL replacement:**

**STEP 1:** Remove old ballast or disconnect from existing lamp holder. Also disconnect any other components such as ignitors, starters, capacitors.

**STEP 2:** Reconnect directly to the existing lamp holder. Install new LED replacement lamp.

Make sure socket is correctly grounded.

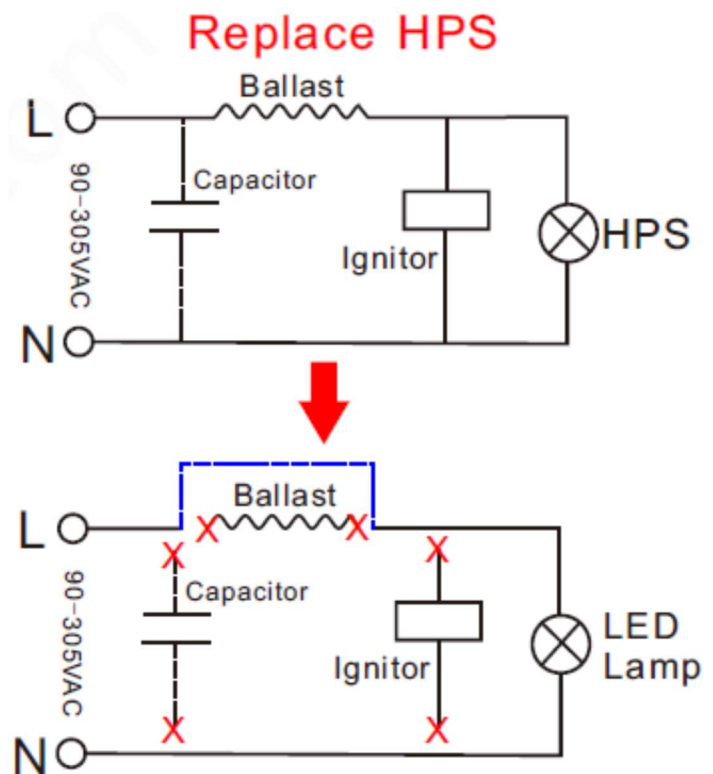

\*In enclosed fixtures, ensure the lamp has enough space for heat dissipation. This will ensure lumen maintenance and extend its working life. When products are used in outdoor fixtures, ensure the space is waterproof and well ventilated.

\*Not for use on a dimmer or remote controls

### CUSTOMER SUPPORT

If you require additional information regarding this luminaire, we invite you to call us. Our business hours are:

Monday – Friday (except holidays): 8:00am to 5:00pm Eastern time.

Phone: 800-221-9092 Fax: 843-278-0001 Email: [info@aamsco.com](mailto:info@aamsco.com)